

INFORMATION



Fences & Structures

allowed in required yard setbacks & interior property

STRUCTURE, for the purpose of this sketch, does not include a main dwelling unit or an structures attached to the main dwelling unit.

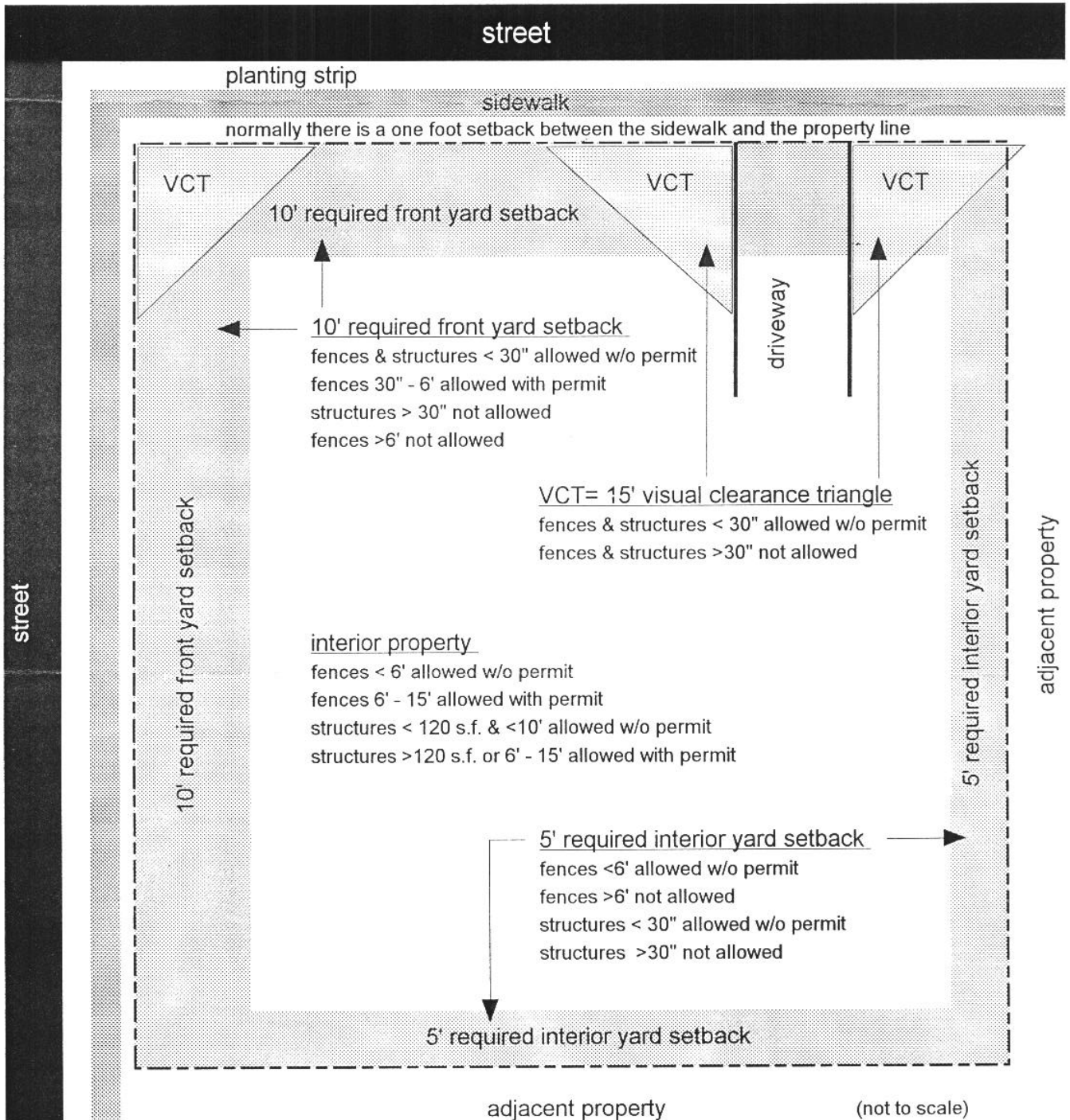

----- indicates property line

INFORMATION



Fence Plans

Cross Section

Indicate size and type of all members being used
 D = dimension (height, width, depth)

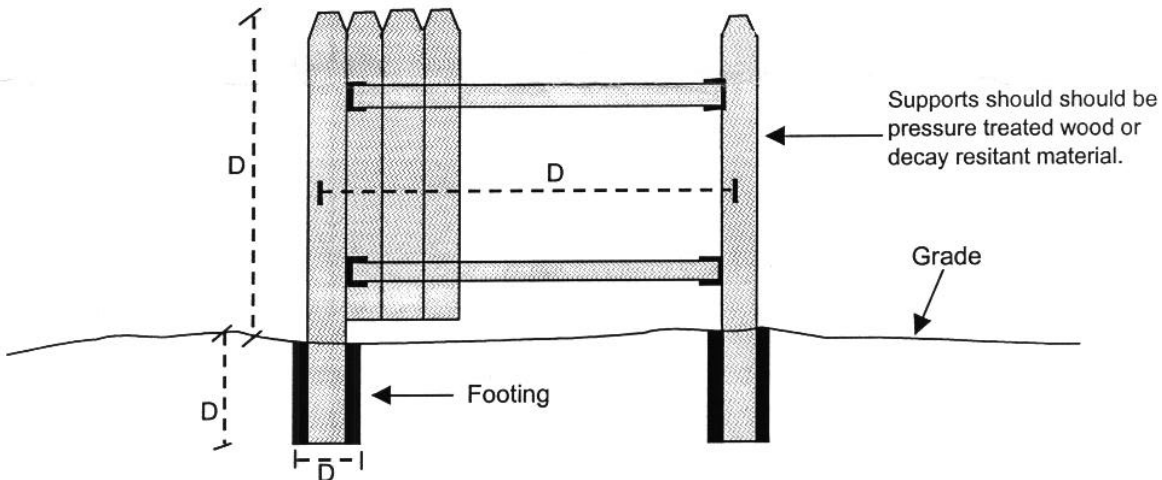

Site Plan

FRONT YARD SETBACK:

--Residences have a 10' front yard setback measured from the street frontage property line.

--A fence up to 30" is allowed in the front yard setback without a permit: Eugene City Code 9.544).

--A 30" to 6' fence may be allowed in front yard setback with permit.

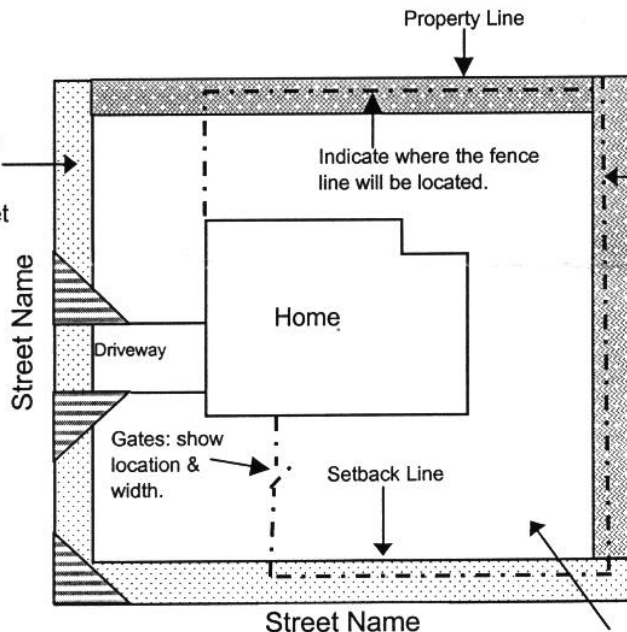

INTERIOR YARD SETBACKS:

--Residences have a 5' interior yard setback measured from the interior property line.

--A fence up to 6' is allowed in the interior setback without a permit (Eugene City Code 9.544).

--Fences over 6' in height are allowed inside the setback area with a permit.

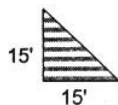

= Visual Clearance Triangle
 Please refer to Visual Clear Zone brochure for restrictions where pedestrian and vehicular traffic may intersect.

Planning & Development
 Building & Permit Services
 99 W. 10th Ave.
 Eugene, OR 97401